



# Securistyle Sterling Advanced Hinge Technical Manual

# Contents

## **Applications**

### **Size and Weight Chart**

Vent Size and Weight Chart

Vent Size and Weight Chart - Fixing Hole Centre Reference Chart – SAT Hinges

### **Assembly Sheets**

SAT 10 Friction Hinge

SAT 12 Friction Hinge

SAT 14 Friction Hinge

SAT 16 Friction Hinge

SAT 18 Friction Hinge

SAT 20 Friction Hinge

SAT 22 Friction Hinge

SAT 24 Friction Hinge

SAT 26 Friction Hinge

### **Fitting Instructions: Vent and Frame Preparation and Fitting**

Vent Preparation and fitting of SAT friction hinges

Frame preparation and fitting of SAT friction hinges

Fitting instructions: Restricting stop SAT hinges

Notes of use of restricting stop (top hung only)

### **Fitting Instructions: Screws and Rivets**

Fixing Screws

Fixing Rivets

Vent Arm End Fixings

Fixing Hole Centre Reference Chart – SAT Hinges

### **Performance, Maintenance and Materials**

Environmental Constraints

Maintenance and Lubrication

Operating Life

Corrosion Resistance

Product and Material Specification

Standards Applicable for Friction Hinges

## Applications

- Optimally engineered for use on structurally glazed vents\*

## Product Features

- Superior self-balancing commercial hinge range with unrivalled weather sealing, providing natural ventilation on projecting top-hung windows.
- Can be used on top hung vents up to 180kg and 2.5m high.
- Manufactured from Austenitic 304 stainless steel for high corrosion resistance.
- Asymmetric stainless steel end cap combined with the plastic endpoint to eliminate metal-to-metal contact for superior durability and strength.
- Composite stainless steel and plastic slider for strength and maximum wear resistance
- Coated pivot rivets for enhanced wear resistance and long-life expectancy
- Crack stop to limit maximum opening.
- Optional cam adjustment device to aid final on-site alignment of heavy top-hung vents.

## Customer Benefits

- Self-balancing hinge providing optimal operating forces and operation on offset glass applications.
- SECURISTYLE® quality and guaranteed performance

\*Offset is ~70mm from nominal

## Disclaimer

It is the responsibility of the user to ensure that they are referencing the latest issue of this document.

Due to our policy of continual product improvement, we reserve the right to alter specifications at any time without notice.

It is the responsibility of the window manufacturer to ensure that the finished window is fully tested in accordance with the relevant standards and meets all required safety specification.

# Vent Size and Weight Chart

Hinge Code (Top Hung)	Max. Vent Weight (Kg)	Min. Vent Height (mm)	Max. Vent Height (mm)	Opening Angle (+/- 2.5°)
SAT10	40	-	600	30°
SAT12	50	600	800	30°
SAT14	60	800	1000	30°
SAT16	70	1000	1200	25°
SAT18	80	1200	1400	25°
SAT20	100	1400	1600	25°
SAT22	120	1600	1800	20°
SAT24	150	1800	2000	20°
SAT26	180	2000	2500	15°

## Note:

- Vent height/width is measured from rebate to rebate (not overall size or outer frame size) on conventional windows or glass size on structurally glazed windows e.g. curtain wall panels whichever is the greater dimension. For maximum vent height and widths not stated, consult profile manufacturers for recommendations on requirements of system strength and sealing.
- Vents of 100Kg or higher, must be fitted with S7280 Cam adjustment devices, which are optional on lighter vents.
- Separate SECURISTYLE® restrictors, vent holding devices, or an operating mechanism may be required to hold large vents in a selected ventilation position against variable wind pressure.
- As with all types of friction hinges, friction cannot be provided until the slider moves. Therefore, when limiting the opening of top hung vents to small/low angles, additional separate device(s) will be required on top hung vents to enable them to remain in a selected ventilation position.

# Vent Size and Weight Chart

## Fixing Hole Centre Reference Chart – SAT Hinges

Hinge Code (Top Hung)	A	B	C	D	E	F	G	H	I	J	K
SAT10	-	42.6	162.9	-	-	117.8	130	-	-	-	212.3
SAT12	-	79.6	192.1	-	-	128.9	144	-	-	-	259.3
SAT14	-	121.3	228.9	-	-	140.8	162	-	-	-	321.3
SAT16	-	156.3	263.9	-	-	152.8	175	-	-	298.7	367.3
SAT18	-	187.3	295.9	-	-	152.9	178	-	-	345.7	414.3
SAT20	173.7	216.9	CSK 318.7	-	-	156.5	184	-	-	396.2	464.3
SAT22	211.2	254.4	CSK 346.2	-	-	192.2	217	-	-	447.2	515.3
SAT24	249.2	292.4	CSK 384.2	-	166	-	297	-	392	497	565.8
SAT26	308.7	351.9	CSK 453.7	-	160.4	-	280.4	-	417	547.1	615.3

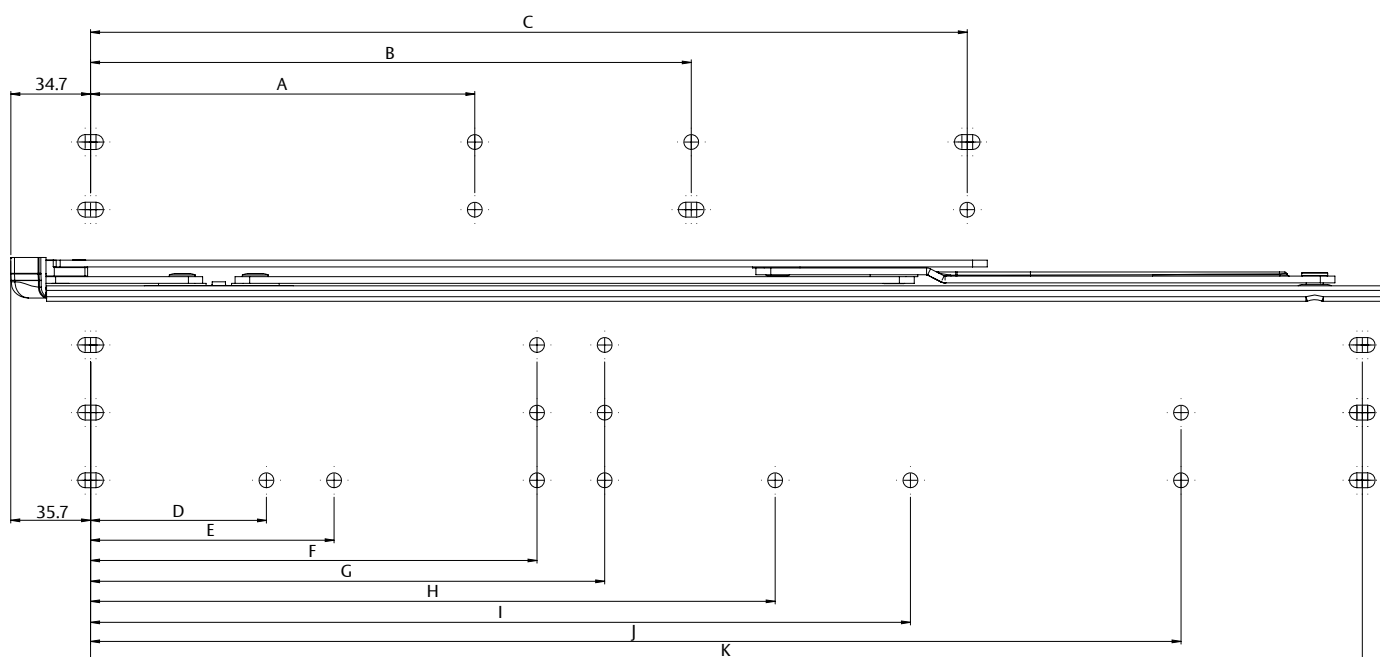

# Assembly Sheet

## SAT 10 Friction Hinge

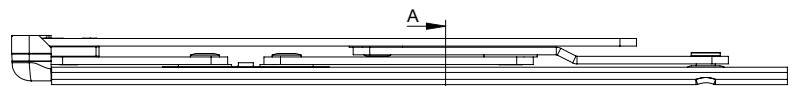
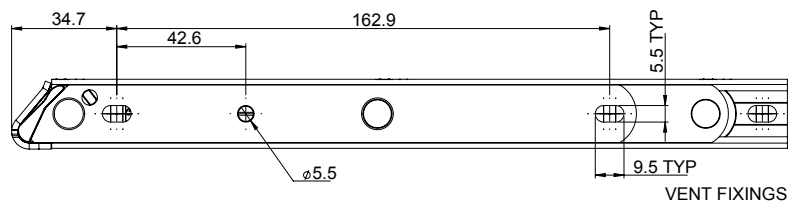
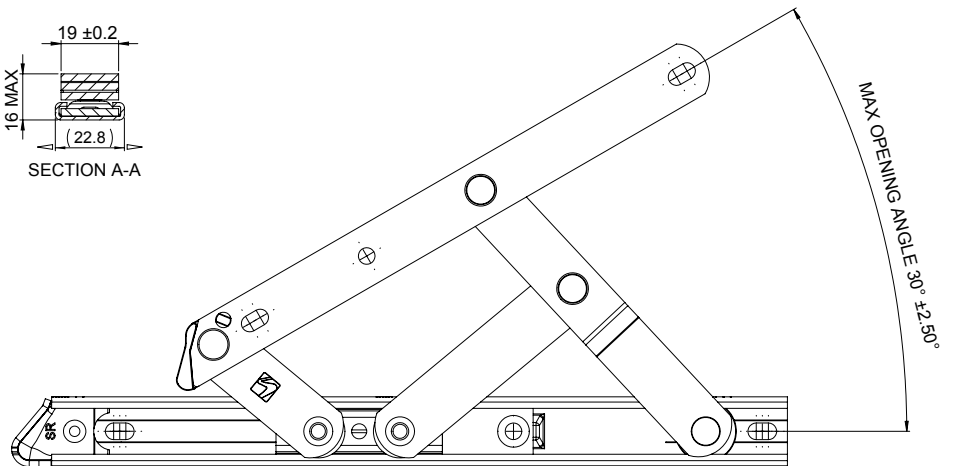
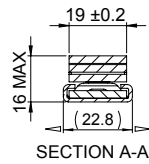
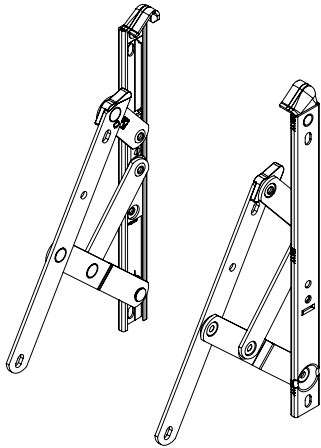

SLIDING STOP SECOND POSITION (= MAX OPENING ANGLE - 5°)

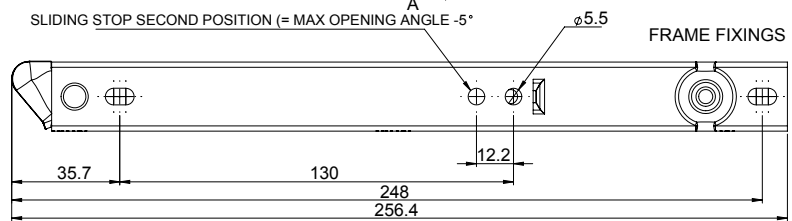

\*All Assembly sheet images from SAT X .pdfs  
Not to Scale, All dimensions in mm

# Assembly Sheet

## SAT 12 Friction Hinge

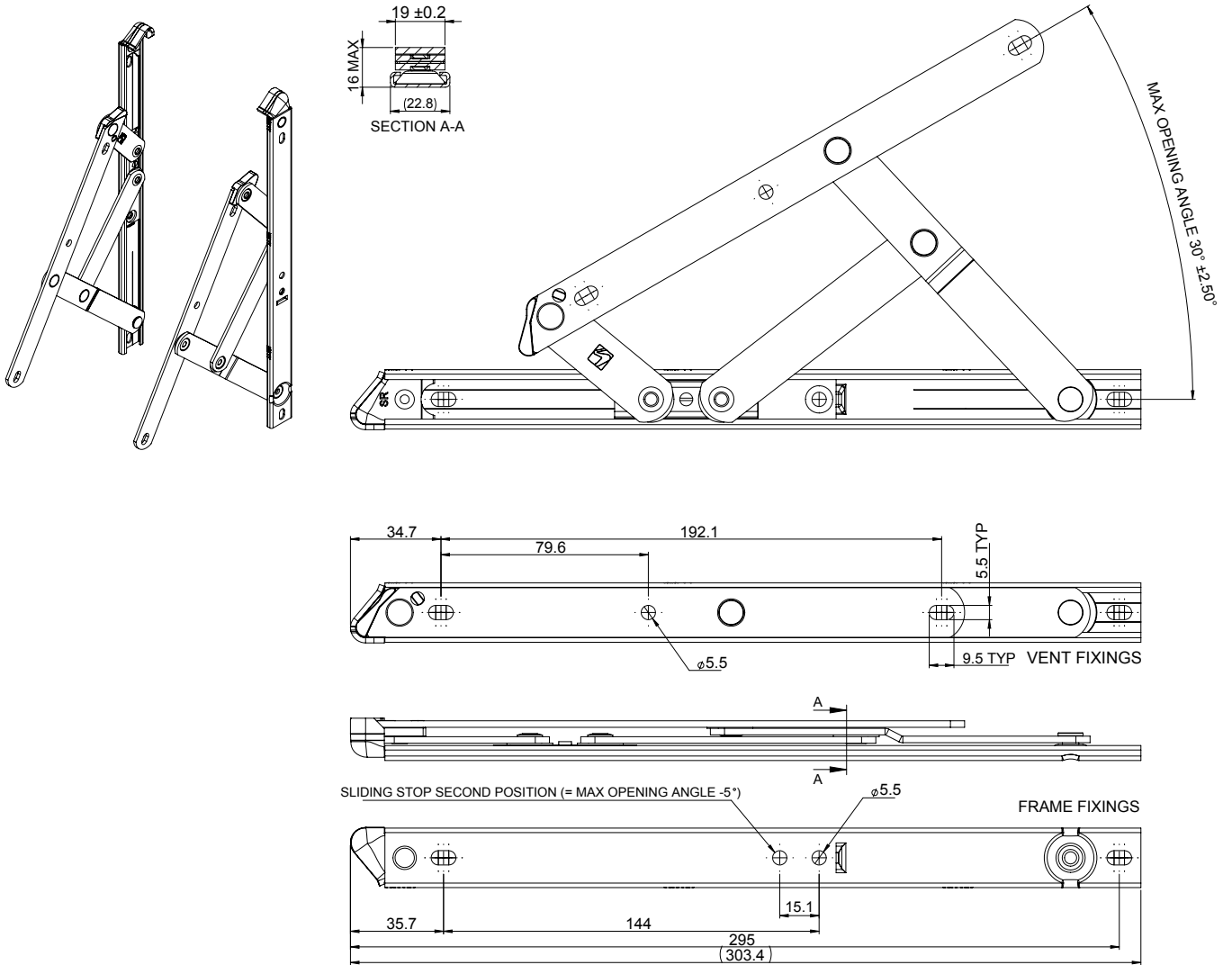

Not to Scale, All dimensions in mm

# Assembly Sheet

## SAT 14 Friction Hinge

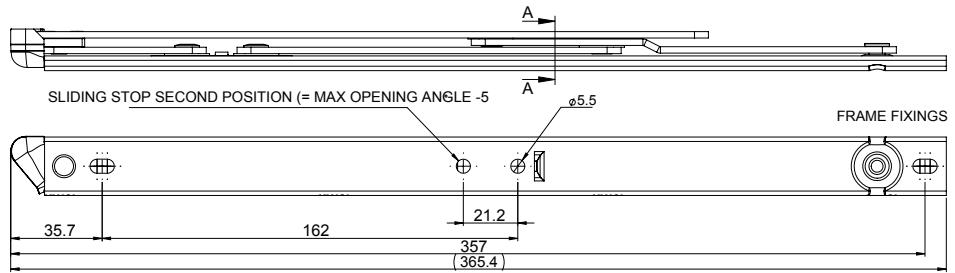
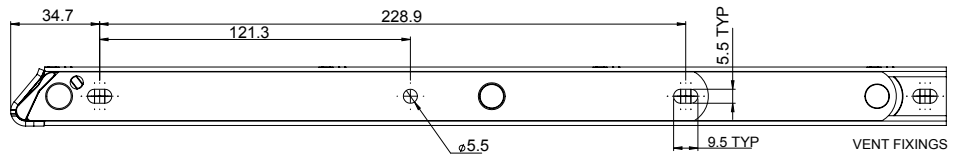
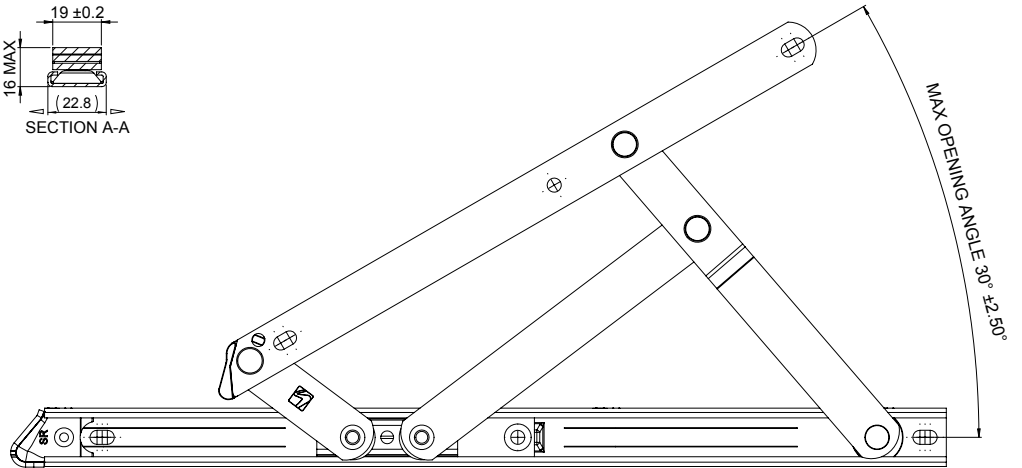
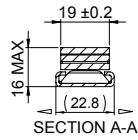
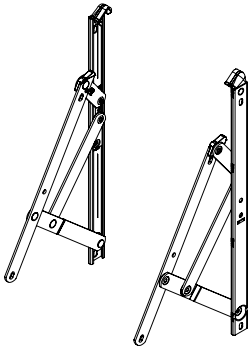

Not to Scale, All dimensions in mm



# Assembly Sheet

## SAT 18 Friction Hinge

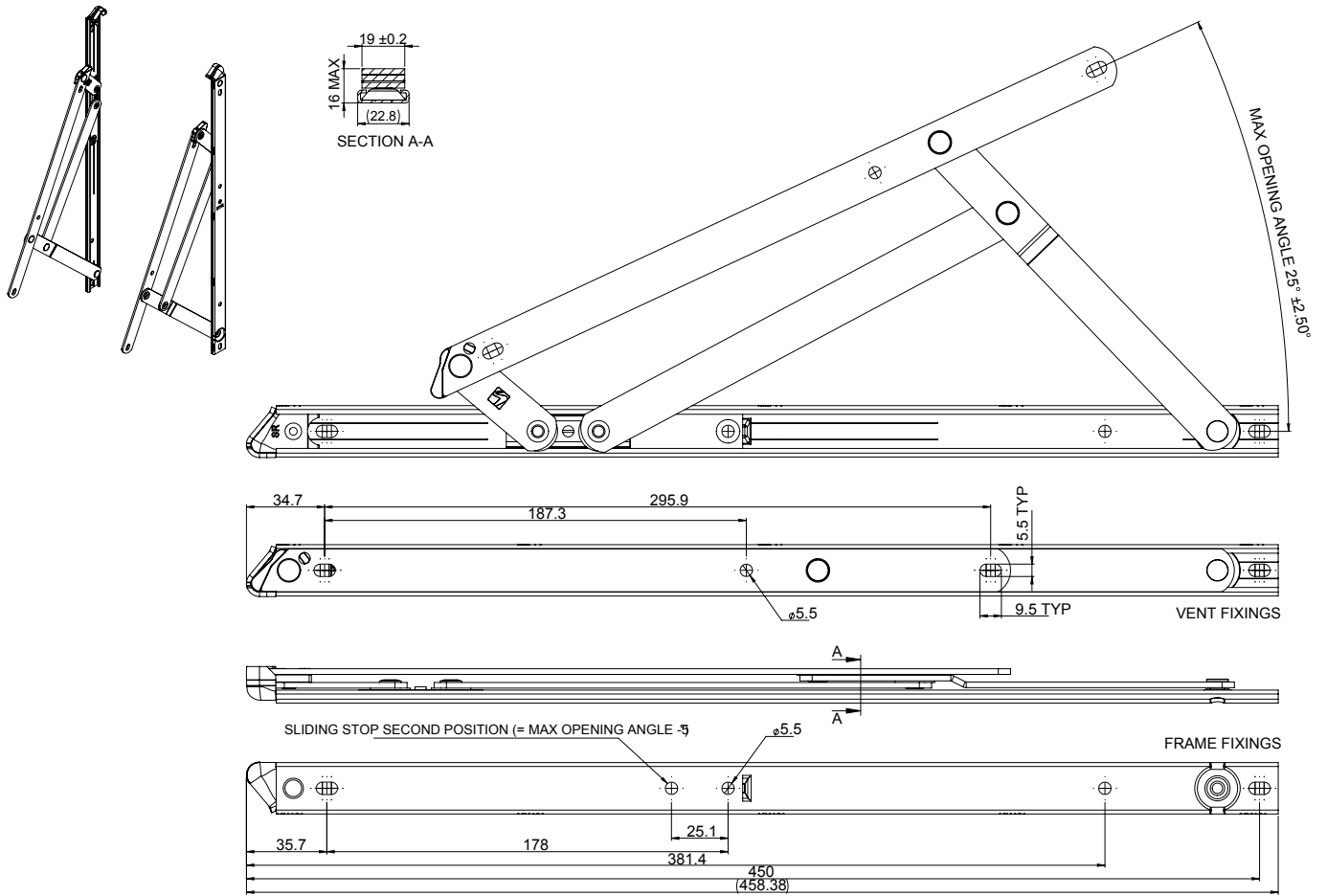

Not to Scale, All dimensions in mm

# Assembly Sheet

## SAT 20 Friction Hinge

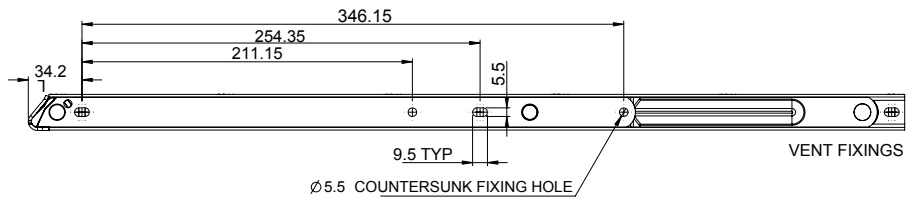
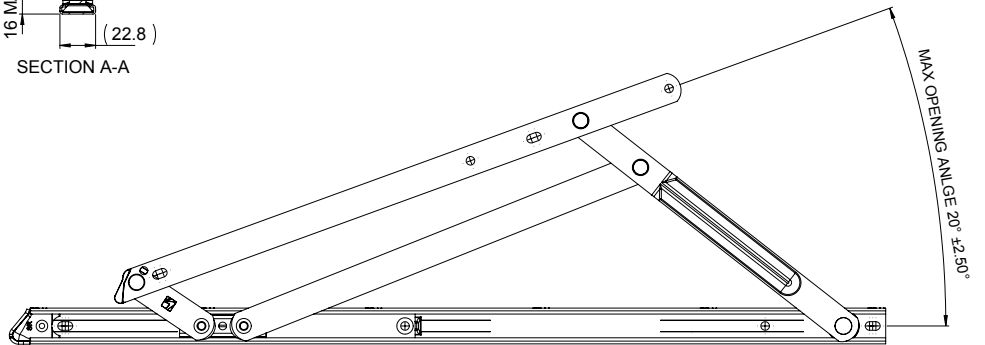
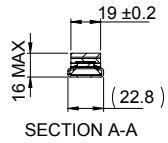
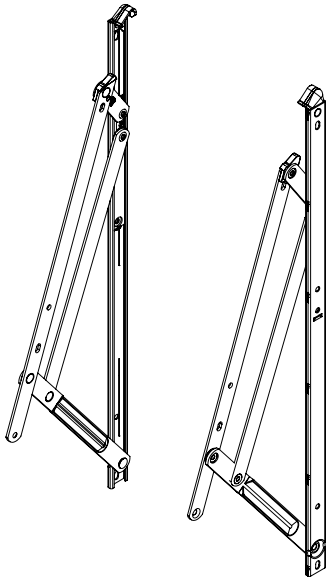

SLIDING STOP SECOND POSITION (= MAX OPENING ANGLE -5°)

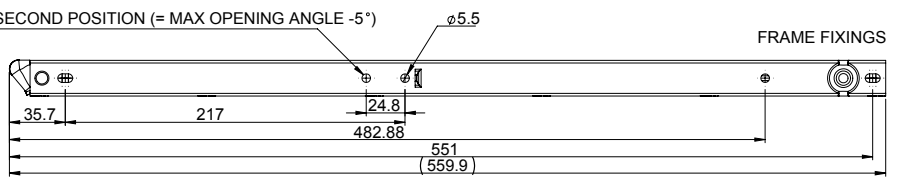

Not to Scale, All dimensions in mm

# Assembly Sheet

## SAT 22 Friction Hinge

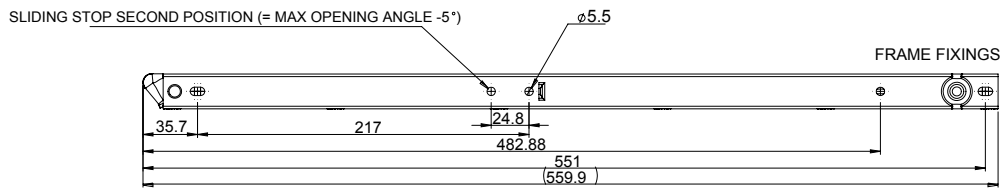
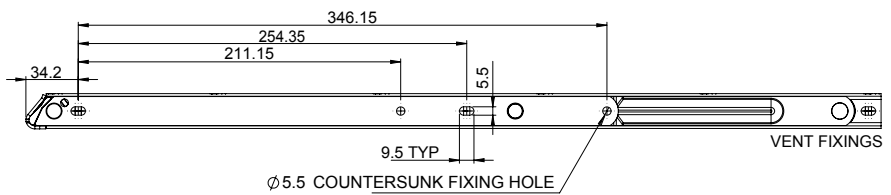
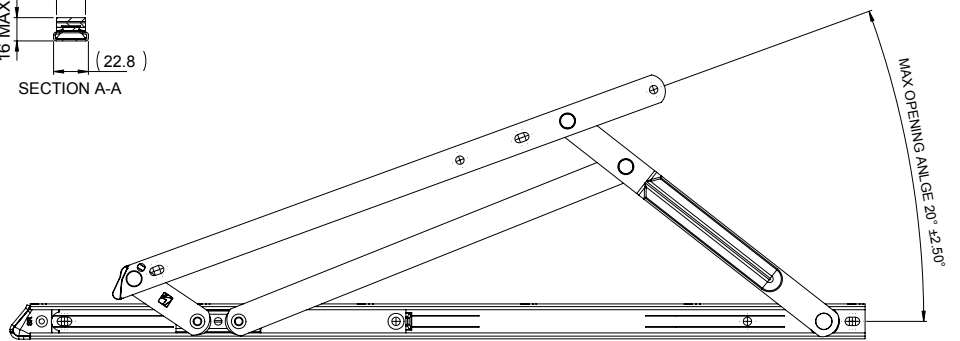
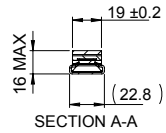
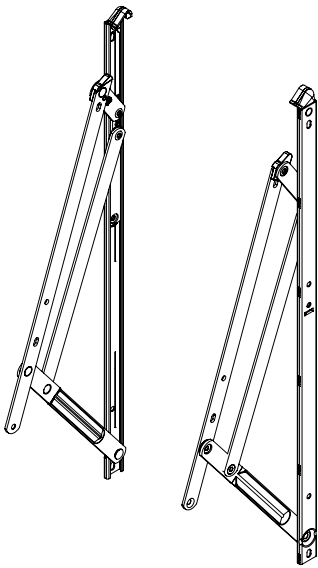

Not to Scale, All dimensions in mm

# Assembly Sheet

## SAT 24 Friction Hinge

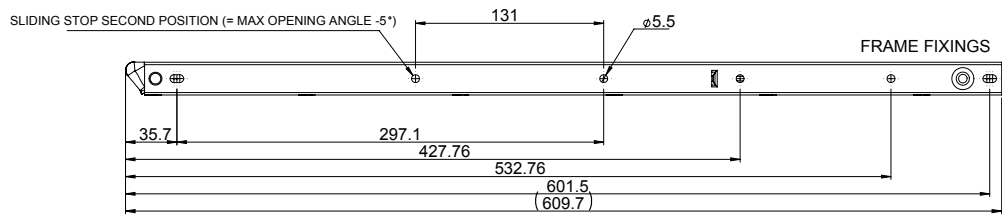
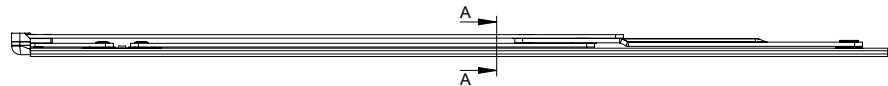
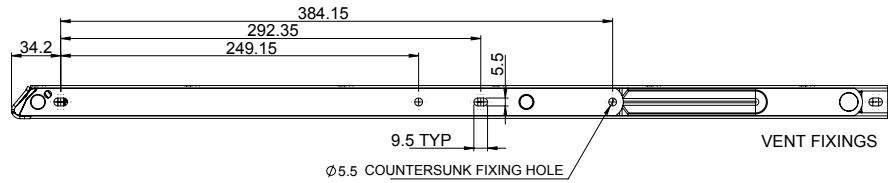
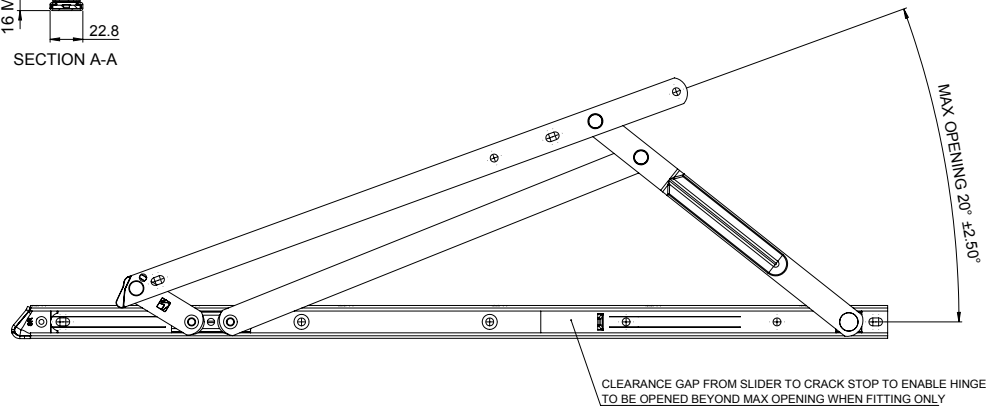
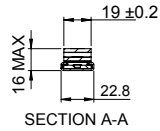
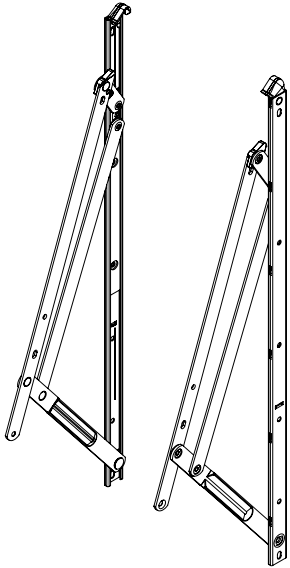

Not to Scale, All dimensions in mm

# Assembly Sheet

## SAT 26 Friction Hinge

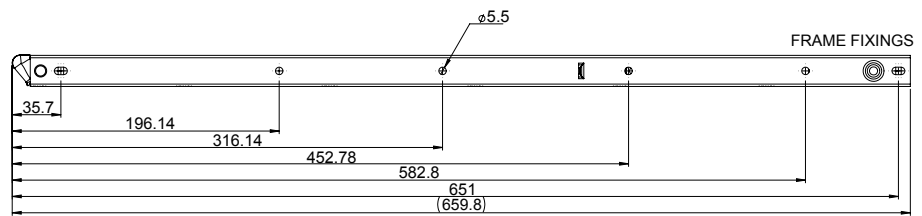
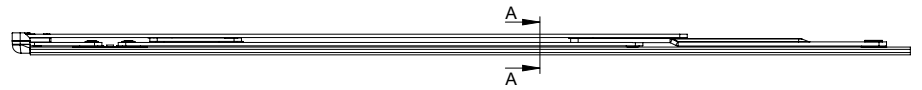
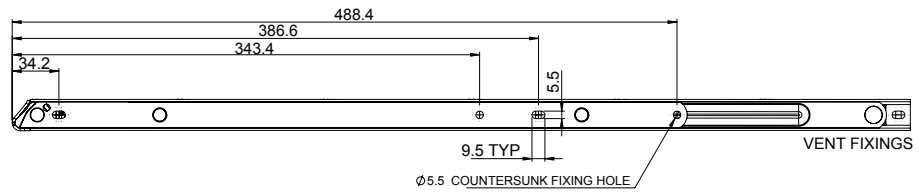
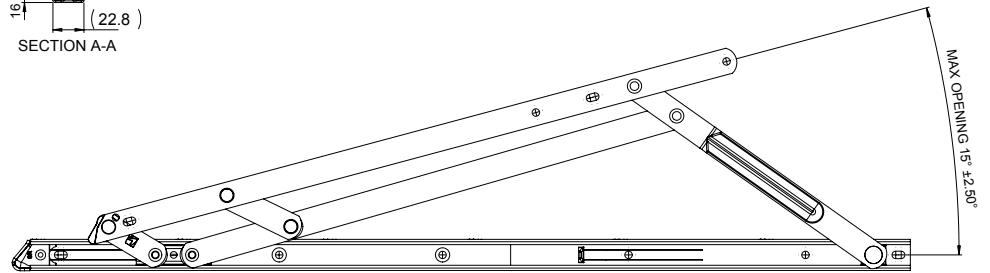
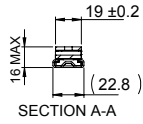
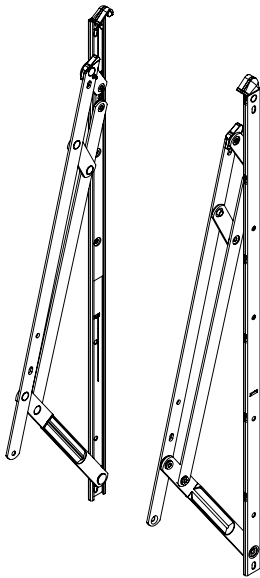

Not to Scale, All dimensions in mm

# Fitting Instructions: Position and Clearances

- SAT hinges are designed to be fitted between two flat and parallel rigid faces that conform to the measurements shown below.
- The vent and outer frame hinge location recess or upstand, if any, must be as shown below.

On profiles where the two parallel faces are not flat use packers to fill any recess to bring the cavity to (16 - 18mm. (See section 2.1.7 for notes on fitting packers)

- The hinge should be fitted with the end cap located into the internal corner of the outer frame (except when using an adjustment device (S7280) fit 2mm away).
- Use all holes and slots to ensure optimum performance and weather sealing.

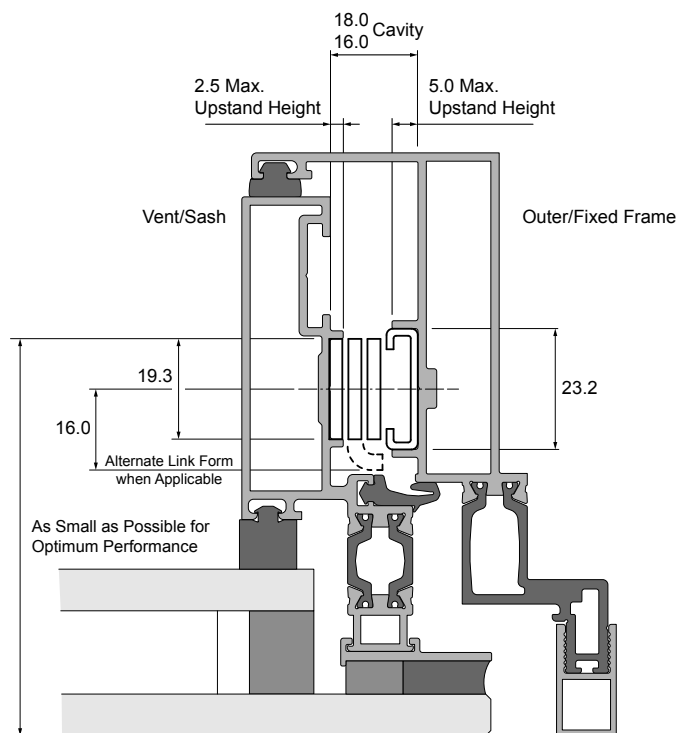

Commercial Inline Hinge Section

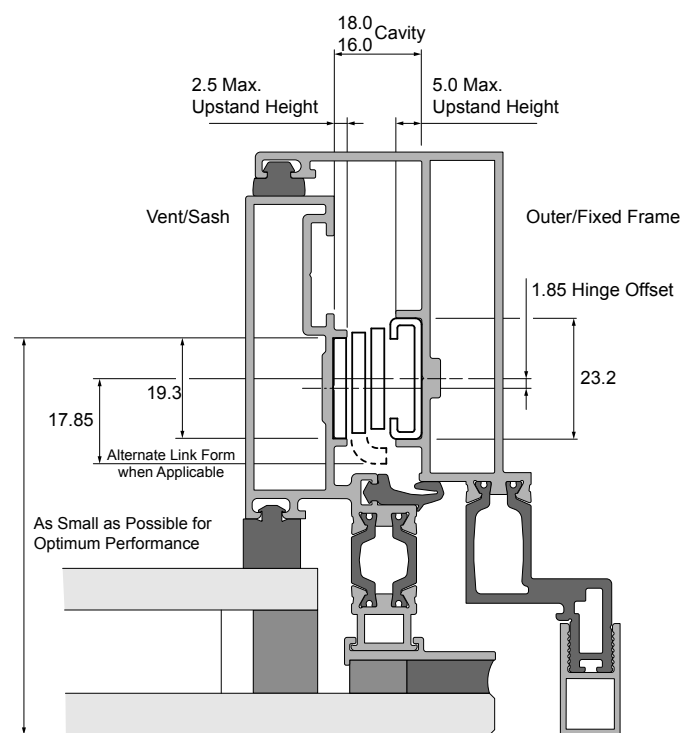

Commercial Offset Hinge Section

# Fitting Instructions: Position and Clearances

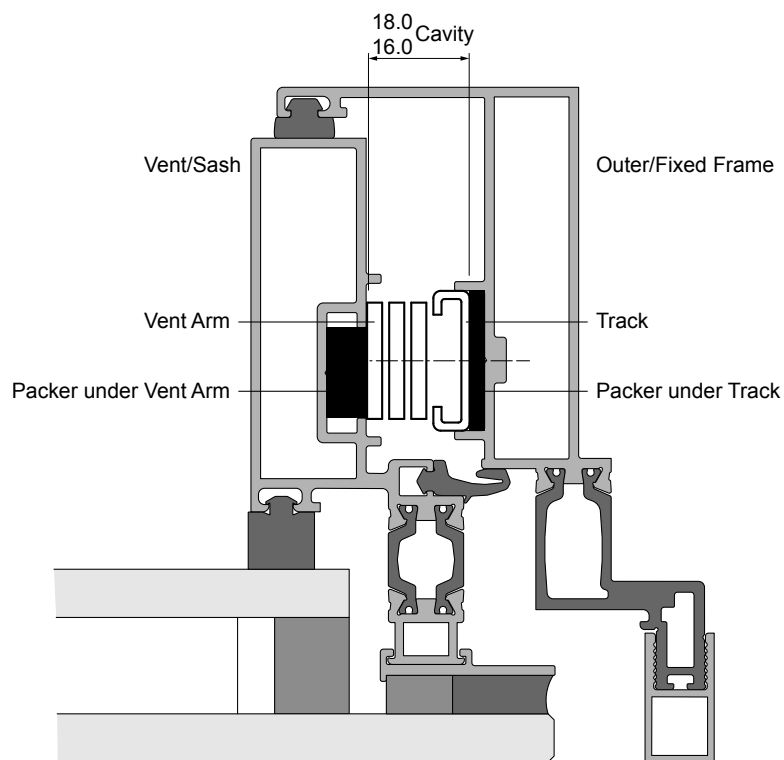

Commercial Hinge with Packer

Please Note: It is important to attach the hinge to the window section and NOT THE PACKER. In some cases, this may mean fixing into the corner cleat.

# Fitting Instruction: Vent and Frame Preparation and fitting Vent Preparation and Fitting

- Position the hinge vent arm against any sideways hinge features or in the hinge location channel on the vent. If the vent does not have hinge location features, determine the correct position by referring to the profile manufacturer's fabrication manual and measuring/markings.
- EITHER:**  
Determine the correct longitudinal hinge position 'x': As show in Fig 4  
**Or:**  
Measure /mark position 'y' of the first fixing hole from the corner of the vent to the dimension shown in Fig. 5 and pre-drill.
- Hold the hinge in place and use it as a template to drill the fixing holes. If the fixings need pre-drilled holes or subsequent adjustment is required, e.g. during installation, drill only the holes which correspond to the slotted hinge fixing holes

SAT Hinges	"x"
16mm Stack Height	16 to 18mm

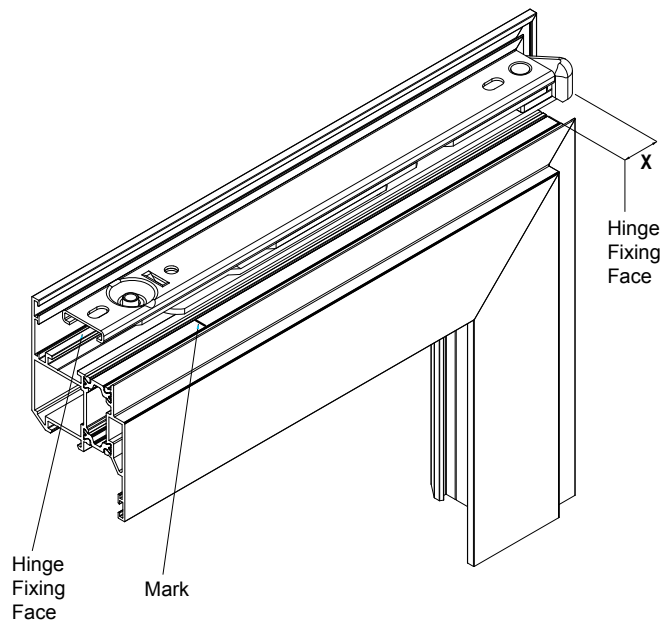

**Note:** When using an adjustment device minus 2mm.

SAT Hinges	"y"
16mm Stack Height	18.0mm +/- 1.0mm

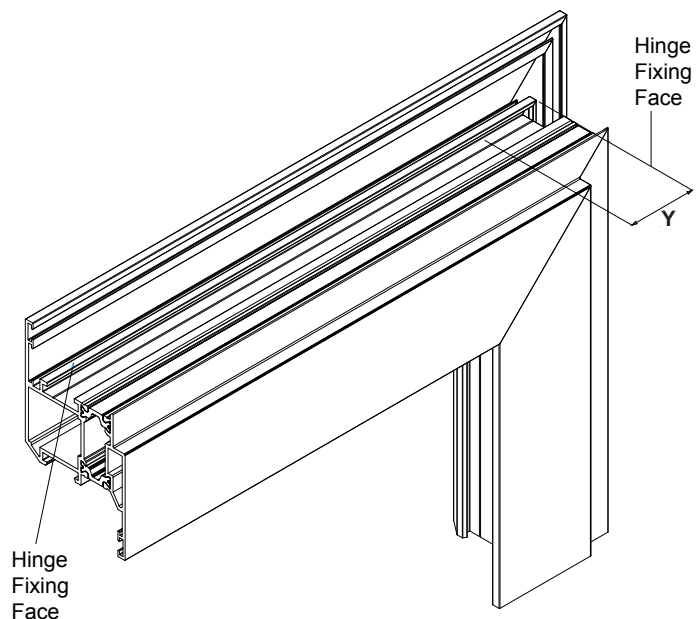

**Note:** When using an adjustment device minus 2mm

# Fitting Instructions: Vent and Frame Preparation

- Position the hinge track against any sideways hinge location features or in the hinge location channel on the frame, commonly the glazing bar clip channel. If the profile does not have hinge location features, determine the correct position by measuring/markings (Fig.1 and Fig 2. will help)
- Position the hinge so that its end cap is located fully into the corner of the outer frame.  
Note: When fitting an Adjustment Device, position the hinge so that the end cap is located 2mm from the corner of the outer frame.
- Hold the hinge in place and use it as a template to drill the fixing holes. If the fixings need pre-drilled holes or if subsequent adjustment is required, e.g. during installation, drill only the holes which correspond to the slotted hinge fixing holes.
- Hold the hinge in place, insert the fixings, to the manufacturer's recommendations, into the pre-drilled holes which correspond with the slotted fixing holes only.
- If further adjustment is required when complete, use the hinge as a template to drill the remaining fixing holes if necessary, and insert fixings into all fixing holes/slots.

# Vent and Frame Preparation

## Fitting with the use of the Hinge Adjustment Device

Note: It is important to drill and fix the device into position whilst installing the hinge. The recommended drill for spigot is 7.0mm.

- When locating the hinge onto the frame, insert the adjustment device into the track and push the locating pin into the pre-drilled hole.

Note: For maximum adjustment in both directions (+/- 2mm).

- The markings on the cam should be at 90° to the markings on the main body. If a 4mm adjustment is required to move the hinge in an upward direction only, the marking on the cam should be at 180° to the markings on the main body.

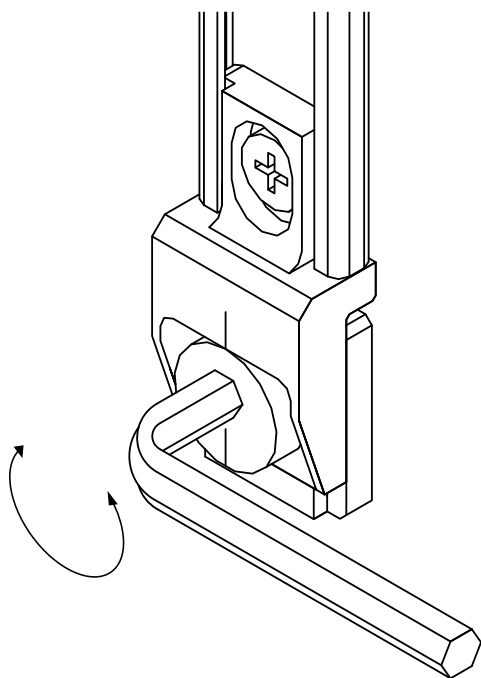

- Once the window has been assembled, open the vent, loosen off any fixings in the slots from around the frame and completely remove the screws from the round holes.
- Using a 5mm hex key, rotate the screw clockwise to adjust up and anti-clockwise to adjust down to reposition the vent in the frame as required. There is 4mm maximum travel.

# Fitting Instruction: Limit Sterling Advanced Stop Hinges

- If the maximum opening angle is required, position the sliding stop so the fixing holes positions align with the lowest holes available in the track. Insert fixing screws in all the visible holes.
- If a restricted opening angle is required, fit the hinges normally. Only use the slots and the lower fixing hole on the track, then with restrictor stop moved clear, either:
  - Open the window to the required angle.
  - Slide the restrictor stop up the track until it touches the underside of the slider.
  - Drill holes through the track using the stop as a template.
  - Insert all fixing screws.
  - Establish the desired angle and pre-drill the restricted position fixing holes in the track before fitting the hinges.
- On some hinge configurations, in order to secure the end cap fixing position (where there is limited access due to opening angle) the hinge can be opened beyond its normal maximum opening angle. Once this fixing is secured the opening angle can be reduced and the sliding stop can be secured.

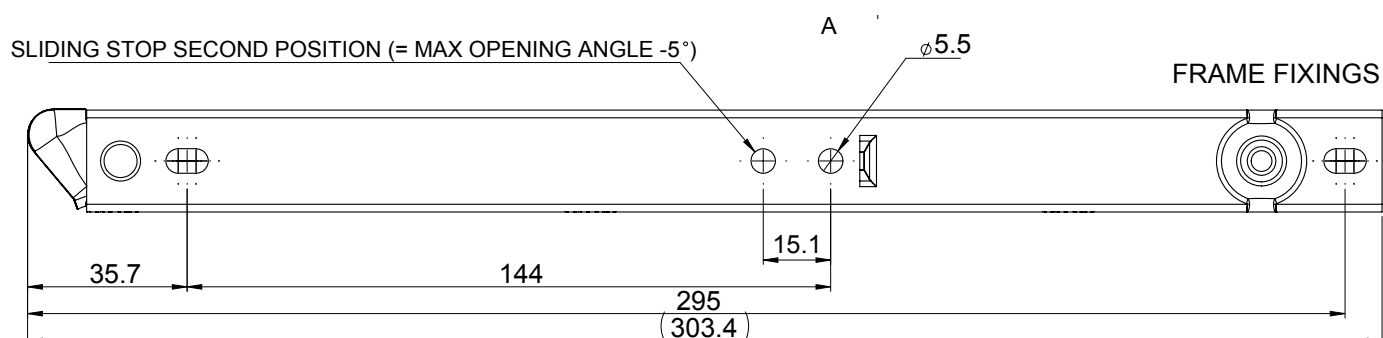

# Fitting Instructions: Screws and Rivets Fixing Screws

- SECURISTYLE® recommend the use of M5 or no.10 pan head screws for fixing the vent track and frame track (channel) on all Parallel Plus Hinges. (Dimensional constraints can be seen to the right).
- All hinge fixings should go through sufficient profile thickness or into screw channels. If this cannot be achieved, Rivet Nuts or similar should be used to provide a strong thread.
- Screw manufacturer's recommendations must be adhered to at all times and if any instructions are supplied by window system manufacturers / suppliers, it is important they are followed.
- Extreme care must be taken not to strip the thread as deterioration in performance will result.
- Austenitic and certain types of modified Martensitic fixings provide superior corrosion resistance when subject to BS EN ISO 9227 / BS EN 1670.

**Note:** It is the responsibility of the window manufacturer to ensure that all fixing screws and rivets have adequate strength to support the weight of the window vent and the forces exerted upon it over the full life of the window.

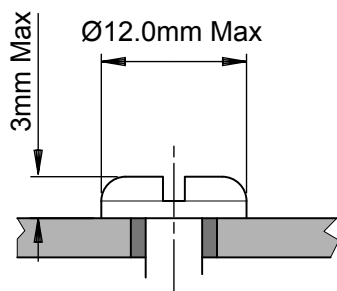

Pan Head

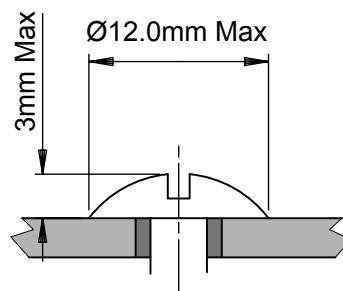

Mushroom  
Head

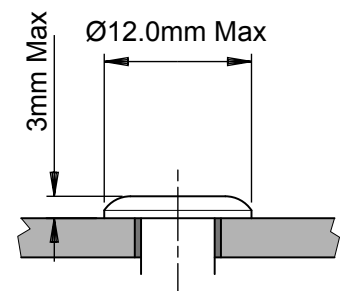

Standard  
Dome Head

# Fitting Instructions: Screws and Rivets Fixing Screws

- Fixing rivets (pop and peel blind rivets) should be 5mm in diameter and of a length to suit the total riveting thickness as recommended by the rivet manufacturer. The following additional constraints must be adhered to: -
  - Head maximum sizes must not exceed those shown below.
  - All rivet manufacturer's recommendations must be observed.
  - Only stainless-steel rivets are recommended for use by SECURISTYLE® Ltd.

**Note:** It is the responsibility of the window manufacturer to ensure that all fixing screws and rivets have adequate strength to support the weight of the window vent and the forces exerted upon it over the full life of the window.

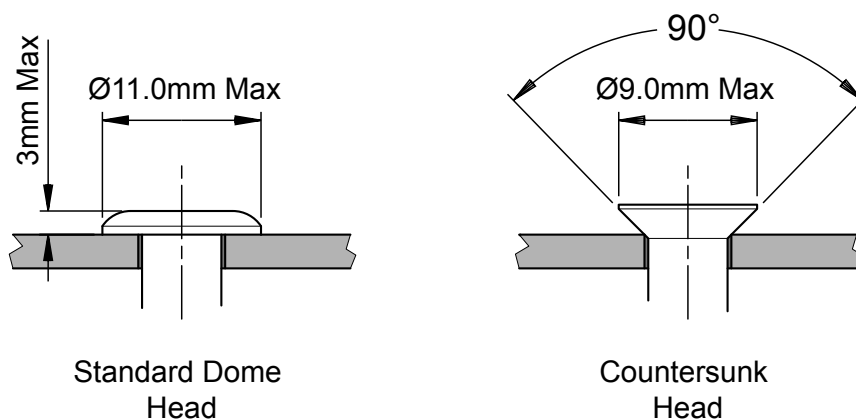

# Fitting Instruction: Screws and Rivets Vent Arm End Fixings

- On some hinge variants, the end vent arm fixing holes must be fitted with a countersunk head screw of a length to ensure that the head is flush/sub-flush to maintain a clear, flat surface. Where the vent arm is being fixed directly onto the face the following are recommended:
  - M5 countersunk screw screwed into a rivet nuts
  - No.10 self-tapping truncated countersunk head screw for fixing into a section.

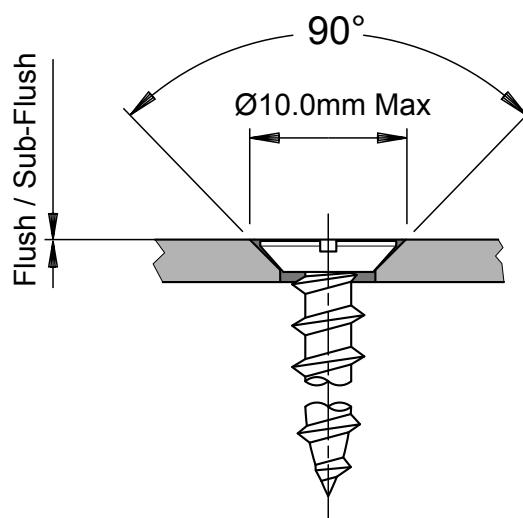
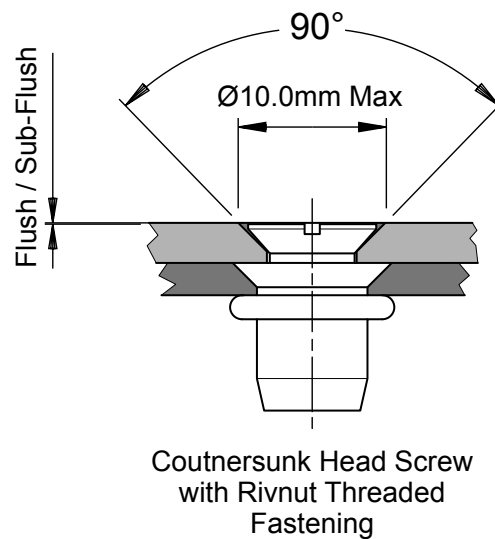

# Performance and Maintenance

## Environmental Constraints

Normal operating conditions for all hinges are:

- Operating temperature range: -20°C to +60°C
- Operating humidity range 10% relative humidity to 95% relative humidity
- The materials used will not degrade due to ultraviolet light or when using neutral acidity non-solvent cleaning chemicals at a rate faster than other parts of the window assembly.

## Maintenance and lubrication

- As with most mechanical devices, hinges require periodic maintenance and lubrication. The hinge in general, and particularly the pivots, sliding parts, and track, must be kept free from dirt, debris, and any obstructions at all times.
- At time of Installation - lubricate all pivot points with general light engineering oil and wipe away excess. One drop per pivot is sufficient.
- Every Five Years - carry out the following checks:
  - Clean any dirt or debris from the hinge and clear any obstructions from the pivots, sliding parts, and track.
  - Apply lubrication.
  - Check the tightness and security of all fixing screws and rivets.

## Operating Life

- To attain optimum operating life all criteria listed above under environmental constraints and maintenance and lubrication must be adhered to.
- All SAT hinges will function normally for up to 30,000 cycles under normal conditions of use. This performance is subject to compliance with SECURISTYLE® installation and maintenance instructions.

## Corrosion Resistance

- When subjected to neutral salt spray test to BS EN 1670: 2007 the hinge remains functional. There is no significant surface pitting caused by corrosion. Some surface discolouration is to be expected.
- If a hinge is fitted in an area where it is exposed to a corrosive atmosphere, e.g. salt-laden sea air in coastal locations, we recommended that in addition to the general maintenance and lubrication:
  - All metal surfaces are lightly coated with lubrication oil or sprayed with a proprietary anticorrosion spray. It is important to follow the manufacturer's instructions for any products used.
  - Maintenance operations may need to be carried out more frequently. This is dependent on the severity of the prevailing conditions.
- When subjected to neutral salt spray test to BS EN 1670: 2007 the hinge remains functional. There is no significant surface pitting caused by corrosion. Some surface discolouration is to be expected.

# Product and Materials Specification

## The following is a guide to the materials used for SAT Hinges.

- All surface finishes are of good commercial quality.
- 2.5mm and 3.0mm stainless steel components (links) are of cold rolled finish and are edge dressed to remove the sharp edges as far as is practical.
- 0.9mm stainless steel components (track) are of bright cold rolled finish.
- Stainless steel components will not display surface blemishes, pits or scratches of greater than 20 sq. mm or 0.25mm maximum depth.
- Plastic components are of uniform finish and colour. Visible surfaces will not display blemishes, pits or scratches of greater than 15 sq. mm or 0.2mm maximum depth.

## Standards Applicable for Friction Hinges

The relevant standards applicable are:

- Austenitic Stainless Steel
  - Links - Stainless steel to BS EN 10088-2 GRADE 1.4301: 2014
  - Track - Stainless steel to BS EN 10088-2 GRADE 1.4301: 2014
  - Pivot Rivets - Stainless steel to BS EN 10263-5 GRADE 1.4567: 2017
- Other Materials for Friction Hinges.
  - Slider Inner - Stainless Steel to BS EN 10088-2 GRADE 1.4301: 2014
  - Slider Outer - ACETAL Homopolymer (Delrin)
  - Friction Screw - Austenitic Stainless steel to BS EN 10088-3: 2005 GRADE 1.4305
  - Washer - Nylon 6

## **Securistyle**

Kingsmead Industrial Estate, Princess Elizabeth Way, Cheltenham, Gloucestershire GL51 7RE

**Telephone:** +44 (0)1902 366800 **Email:** [info@securistyle.co.uk](mailto:info@securistyle.co.uk)

**[www.securistyle.com](http://www.securistyle.com)**

Due to a continuous programme of development the company reserves the right to make alterations without notice. (Products which are not a stocked item will be subject to a longer lead time which needs to be agreed with your Securistyle representative).

© ASSA ABLOY January 2026